

**DETAIL B
SCALE 2 : 1**

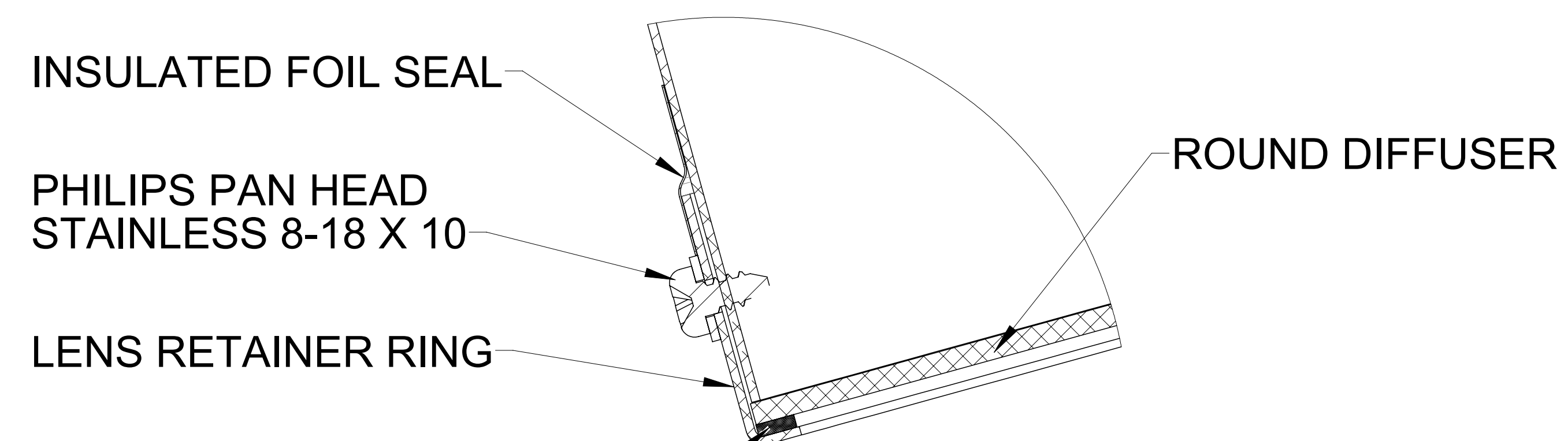
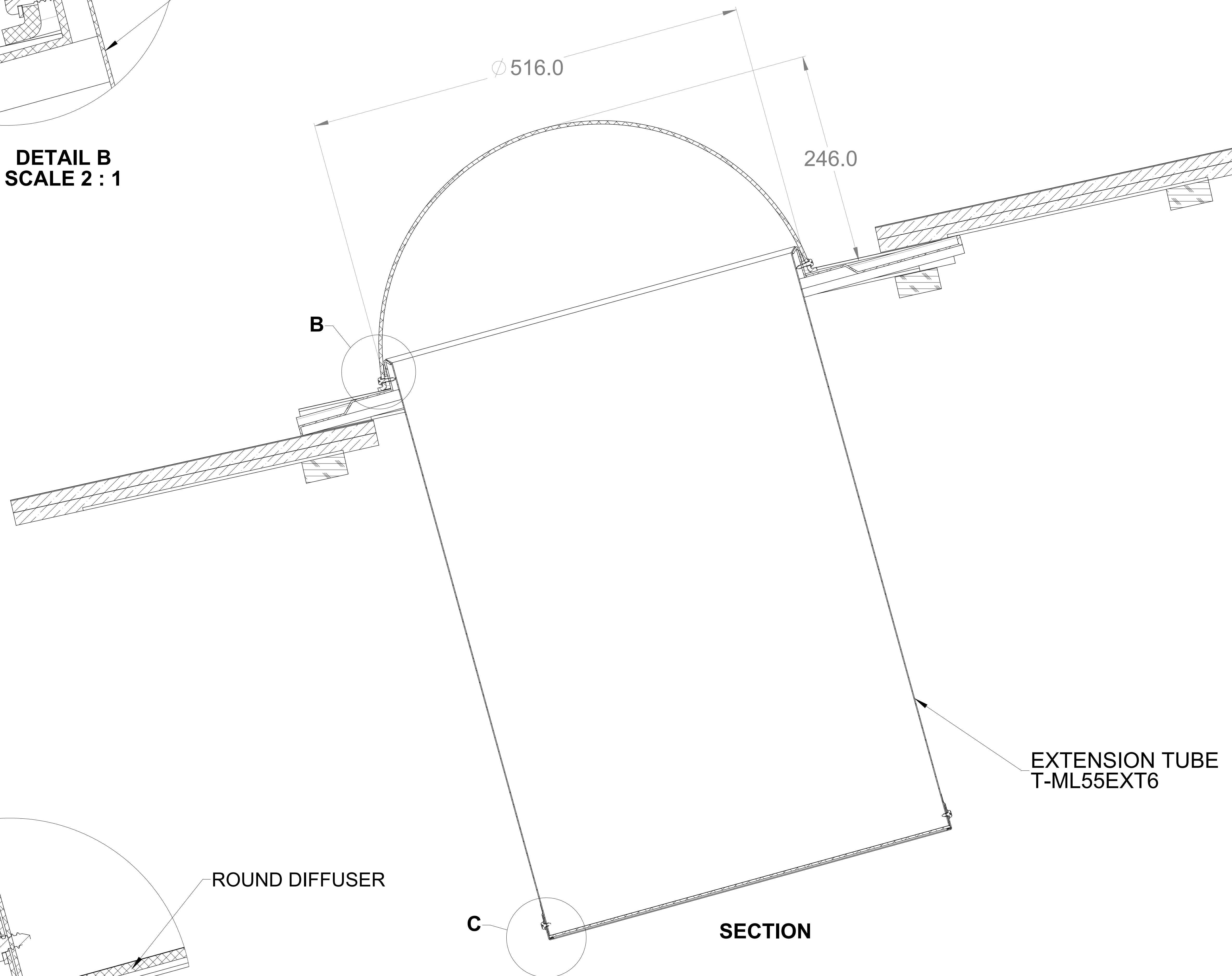
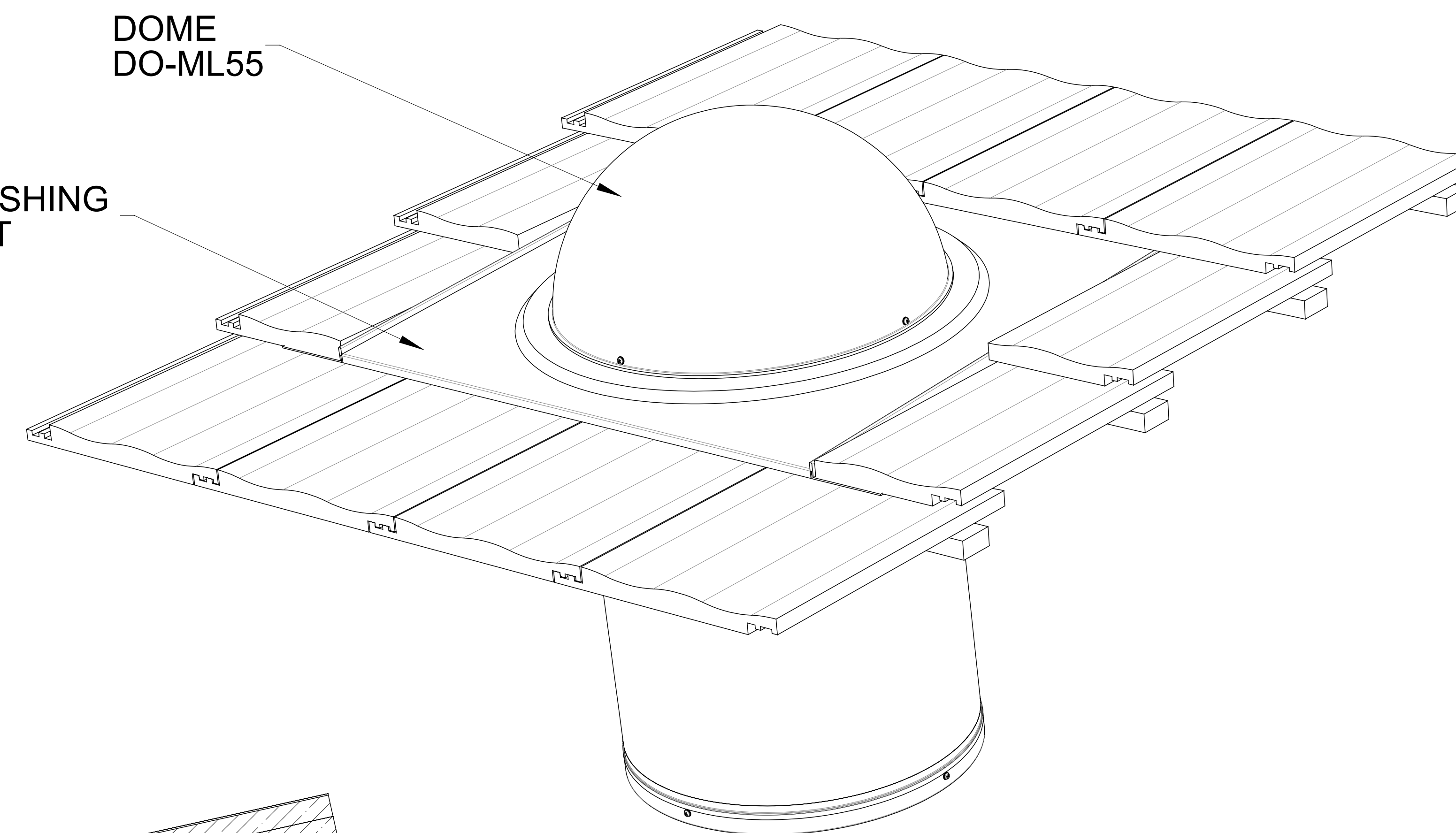

**DETAIL C
SCALE 2 : 1**

Components	Specs
Dome	4.5 mm High Impact Clear Acrylic.
550 Tile Flashing	2 mm Aluminium
Top Tube	0.5mm Aluminium with 98% reflectivity.
Round Diffuser	Acrylic Lens assembled in Aluminium ring

- NOTES**
 1. STRUCTURAL ELEMENTS SHOWN FOR REFERENCE ONLY
 2. ALL DIMENSIONS IN METRIC MM

SOLAR BRIGHT AUSTRALIA PTY LTD

11 Progress Circuit. Prestons. NSW. 2170 Australia.

ALL DIM IN MM	DO NOT SCALE	3RD ANGLE PROJECTION	AS1100	THIS PRINT	Monday, 3 July 2023 3:47:34 PM
THIS IS THE CONTROL DRAWING FOR THE CAD FILE: DRAWING NAME-REVISION.EXTENSION				SHEET SIZE	SHEET NUMBER
GENERAL TOLERANCES (UNLESS OTHERWISE STATED):				A0	1 / 1
X. = ±1.000 XX. = ±0.250					1:10
X.XX. = ±0.025 (X) = REF. DIM.					

DRAWING NAME	REVISION
MAXLIGHT 550 TILED FOR OPEN CEILING	B

