

DETAIL B
SCALE 2 : 1

TEK SCREWS WITH SEAL
HEX HEAD 12-14 X 25
GALVANISED 22 OFF

UNIVERSAL METAL FLASHING
K-FL55MU

BACK FLASH PAN
SUPPLIED BY INSTALLERS

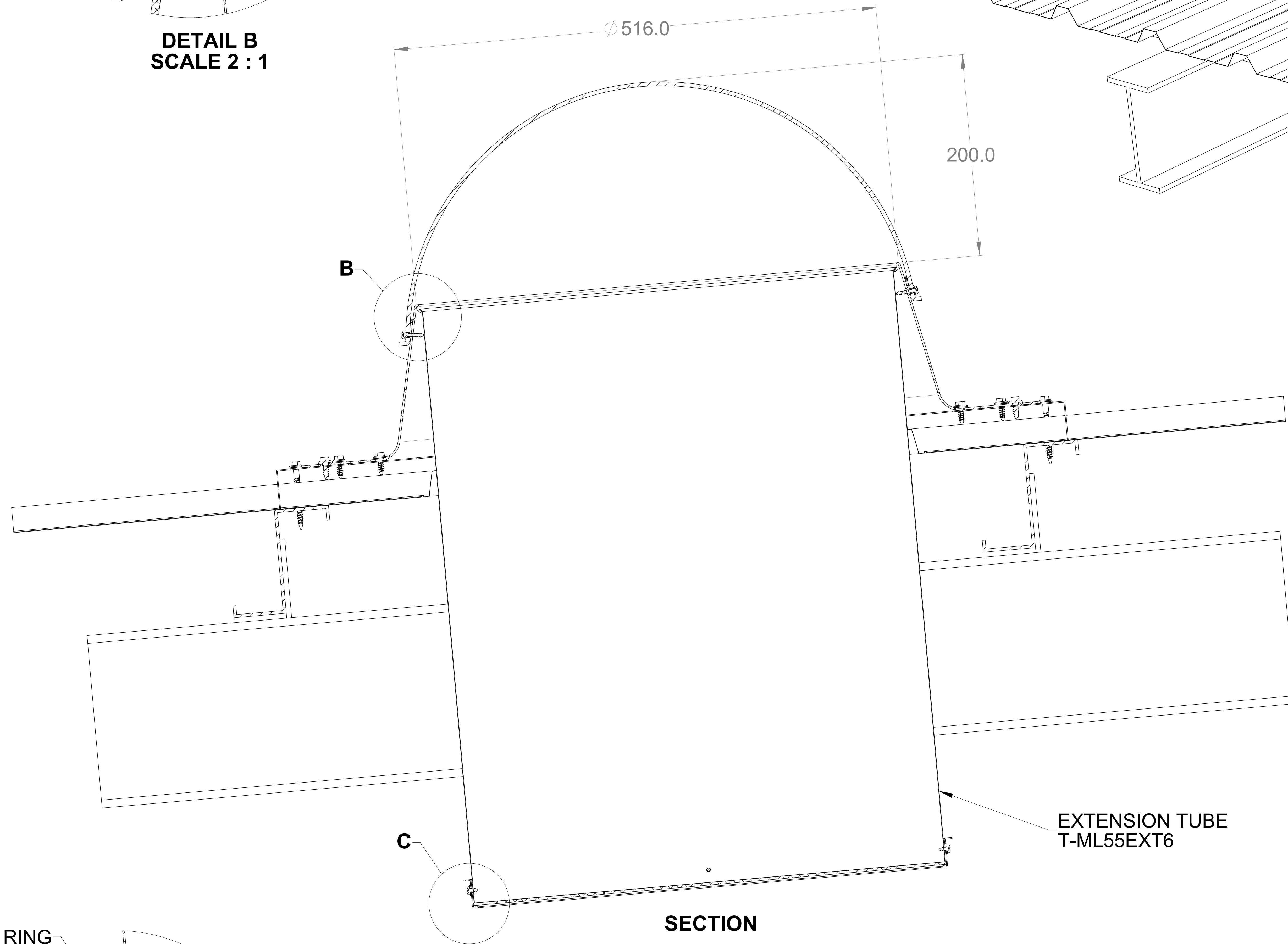
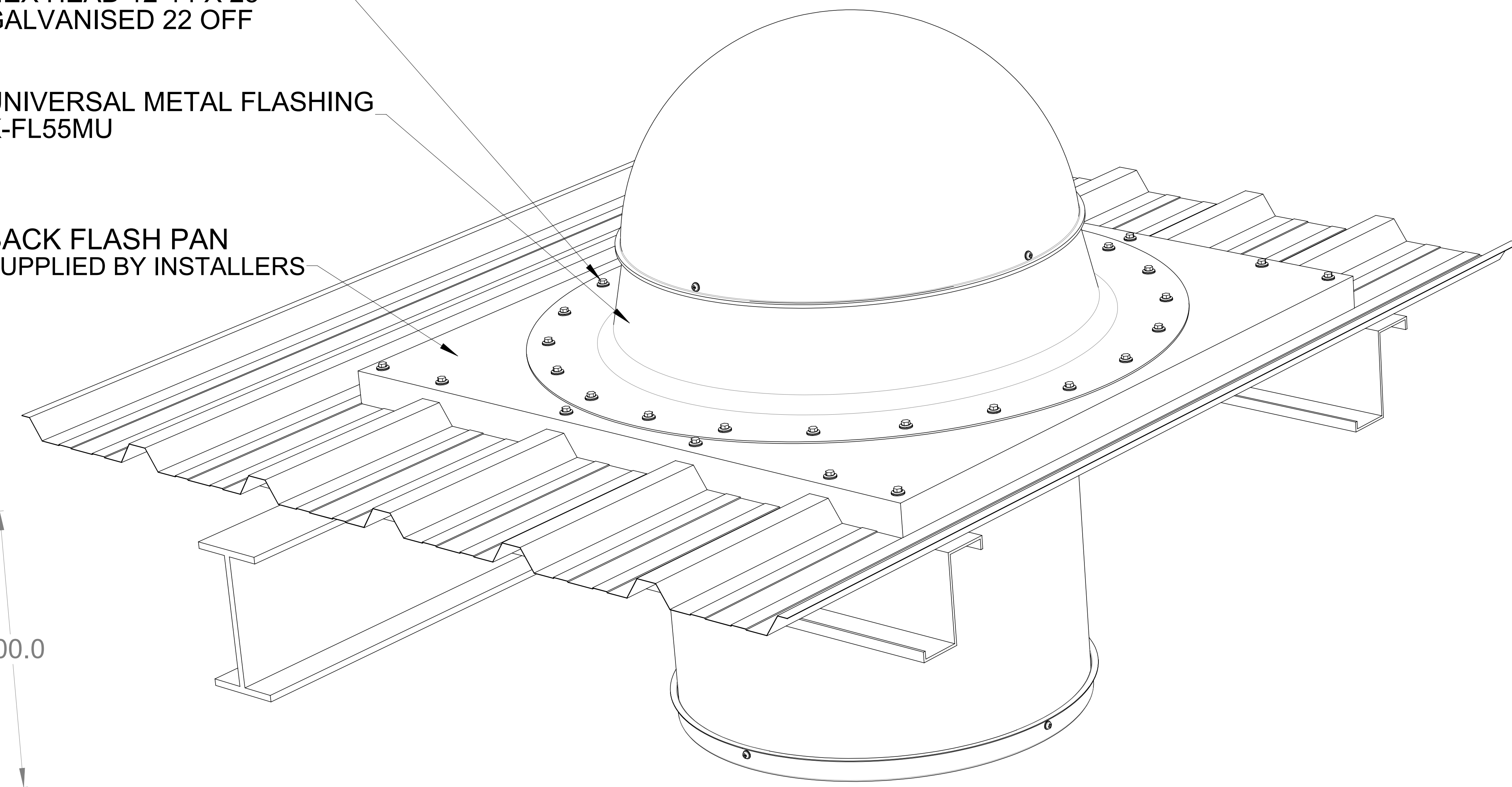

SECTION

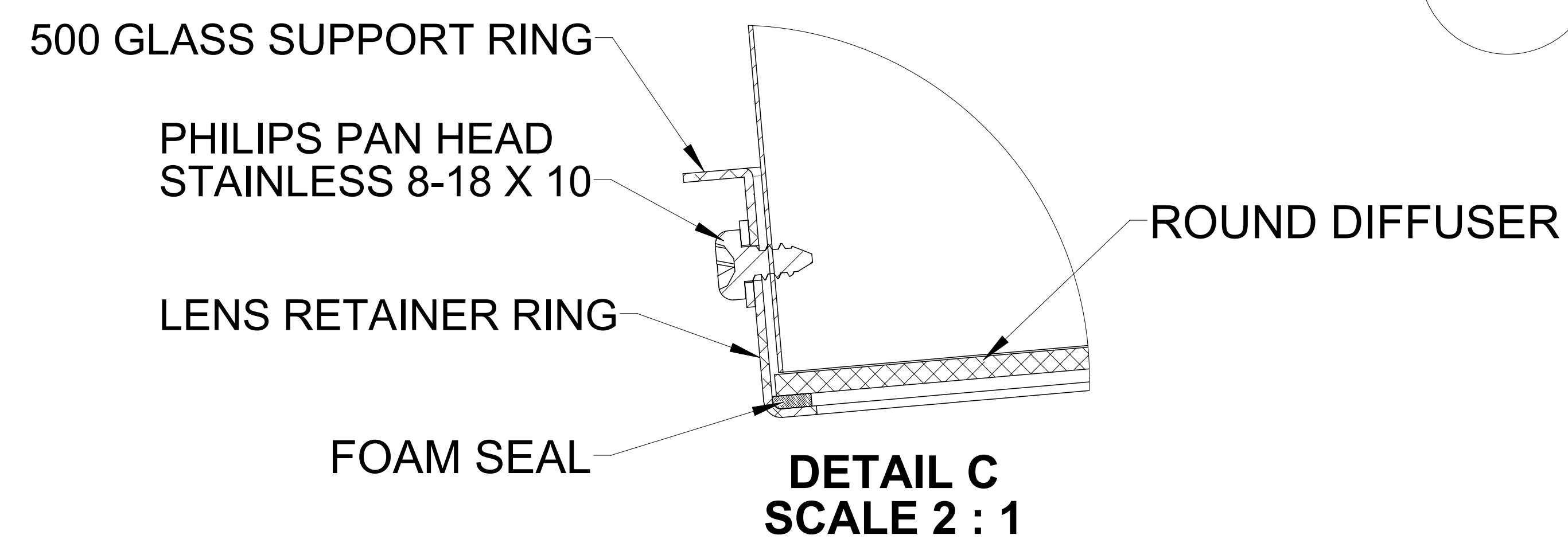

DETAIL C
SCALE 2 : 1

Components	Specs
Dome	4.5 mm High Impact Clear Acrylic.
MAXLIGHT 550 Flat - Round Flashing	2 mm Aluminium
Top Tube	0.5mm Aluminium with 98% reflectivity.
Round Diffuser	Acrylic Lens assembled in Aluminium support ring

NOTES
1. STRUCTURAL ELEMENTS SHOWN FOR REFERENCE ONLY
2. ALL DIMENSIONS IN METRIC MM

SOLAR BRIGHT AUSTRALIA PTY LTD

11 Progress Circuit. Prestons. NSW. 2170 Australia.

ALL DIM IN MM DO NOT SCALE 3RD ANGLE PROJECTION AS1100 THIS PRINT	Monday, 3 July 2023 11:21:21 AM
THIS IS THE CONTROL DRAWING FOR THE CAD FILE: DRAWING NAME-REVISION.EXTENSION	SHEET SIZE SHEET NUMBER SHEET SCALE
GENERAL TOLERANCES (UNLESS OTHERWISE STATED): X. = ±1.000 X.XX = ±0.250 X.XXX = ±0.025 (X) = REF. DIM.	A0 1 / 1 NA

DRAWING NAME

MAXLIGHT 550 UNIVERSAL
FOR OPEN CEILING

REVISION

C

